

# WORLD MARKET®

## Assembly Instructions

### HANDLER SIDE CHAIR

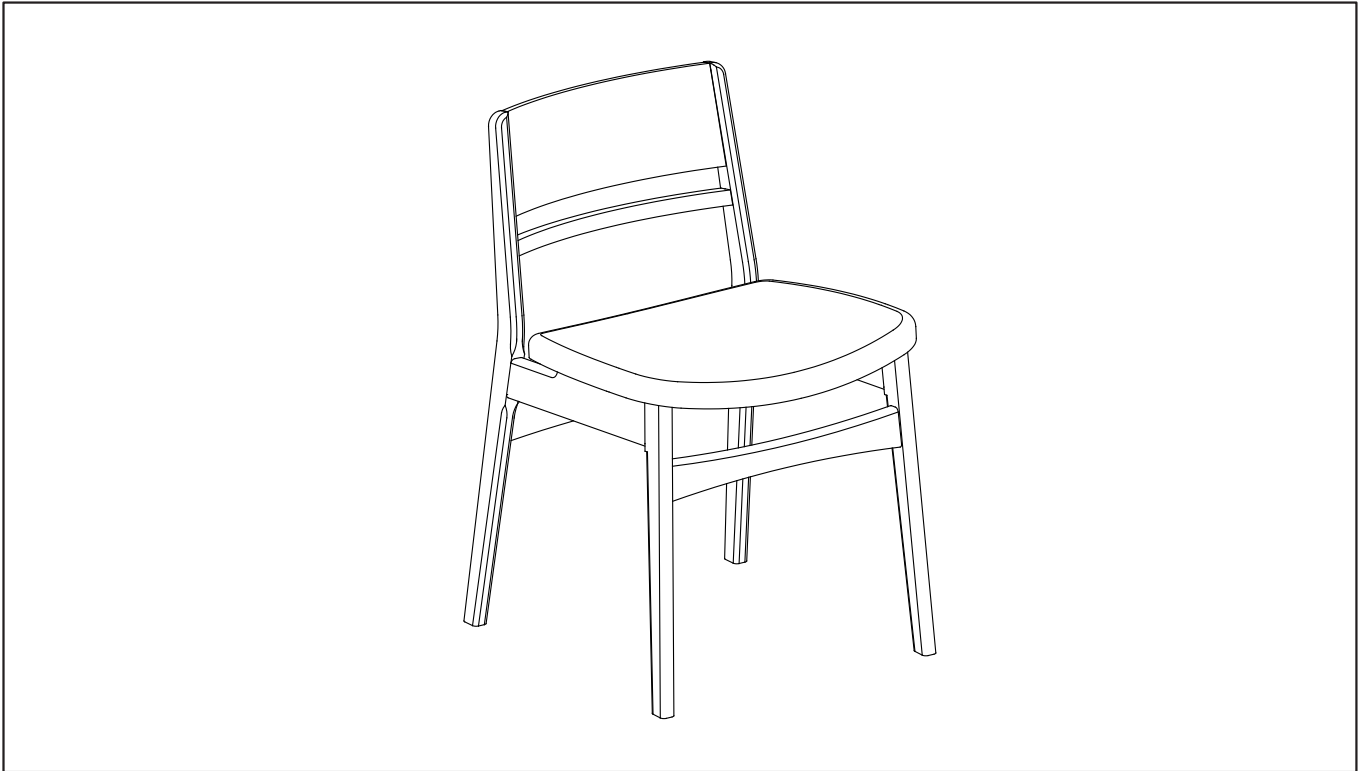

SKU 642730 (Granite), 642731 (Deep Sea Blue),  
642732 (Cabernet), 643479 (Sandstone)





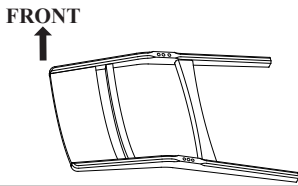

Thank you for your purchase. If you have any questions pertaining to the assembly of this furniture piece, please contact the nearest World Market store. If you are not near a store, please call our customer service call center toll free at 877-967-5362 for assistance.

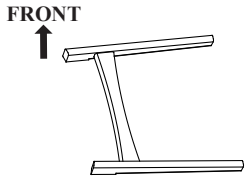
ALL PRODUCTS SOLD AT WORLD MARKET ARE NOT  
FOR COMMERCIAL USE AND ARE INTENDED FOR  
RESIDENTIAL USE ONLY.

# Component List

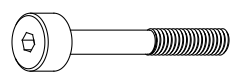
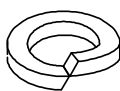
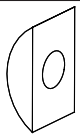
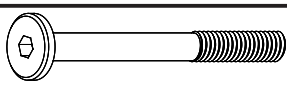
LABEL	PICTURE	DESCRIPTION	QTY.
A		Back Rest	1
B		Seat	1
C		Front Frame	1

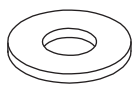
# Hardware List

LABEL	PICTURE	DESCRIPTION	QTY.
H-1		Large Cap Head Screw Ø8 x 70mm	2
H-2		Large Spring Washer M8 x 14mm	2
H-3		D Washer 28 x 15 x 8mm	2
H-4		Allen Bolt Ø6 x 75mm	4
H-5		Small Spring Washer M6 x 11mm	4
H-6		Flat Washer M6 x 13mm	4
H-7		Wooden Plug Ø15.5 x 10mm	4+1(Extra)
H-8		Connecting Barrel Nut Ø6 x 10mm	2

# Tool List

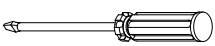
LABEL	PICTURE	DESCRIPTION	QTY.
T-1		Allen Key M4 x 30 x 110mm	1
T-2		Flathead Screwdriver (not included)	1

# Assembly Preparation

## Before Beginning:

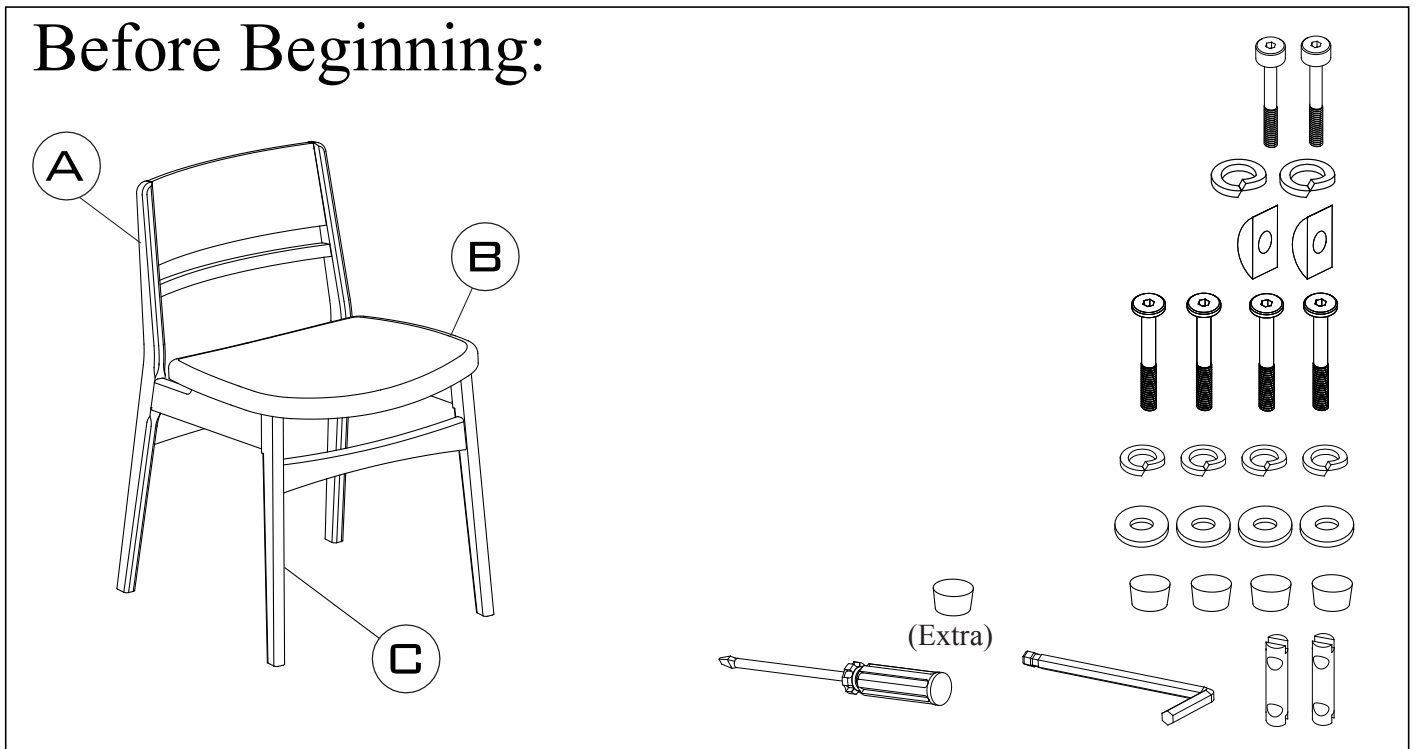

Unpack all hardware bags and components to ensure you have all parts. Take note of bolt hardware size differences and components that may have directional labels (Example: TOP or FRONT).



Depending on your furniture product, foam, packing dust, or residual film or finish may be present on the components. This is normal and can be wiped clean using a non-colored, lint-free dry cloth.



Read the assembly instructions, cover-to-cover. Save any **Care and Maintenance** instructions pages for after the assembly has been completed.



It is always recommended to have 2 adults on hand for assembly.



Do not assemble on hard, abrasive flooring or carpeted surfaces that can damage or get caught in the components during assembly.



Assemble on a clean non-marring surface (such as the product's packing foam).

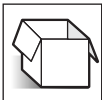

Do not discard any packaging until the product has been fully assembled.



In case of missing parts, please contact your nearest World Market store or call our customer service call center at 1-877-967-5362.



**WARNING:** Small parts are a choking hazard. Adult supervision is required before, during, and after assembly.

# Assembly Steps

## Step 1

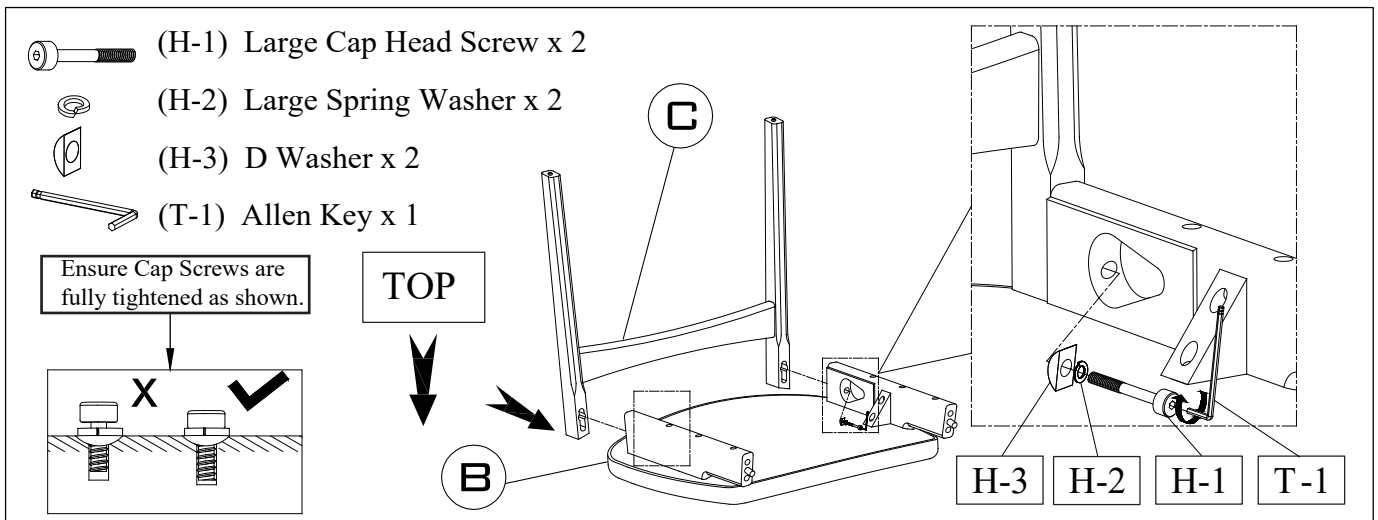

Position Seat (B) upside down onto a padded, no-marring surface. Position Front Frames (C) onto the front of Seat (B) as shown. Insert Large Cap Head Screw (H-1), Large Spring Washer (H-2) and D Washer (H-3), through the holes in each Seat (B)'s frame into the receiving holes on the Front Frame (C), arrange the hardware in the order as shown. Do not yet fully tighten Bolts.

## Step 2

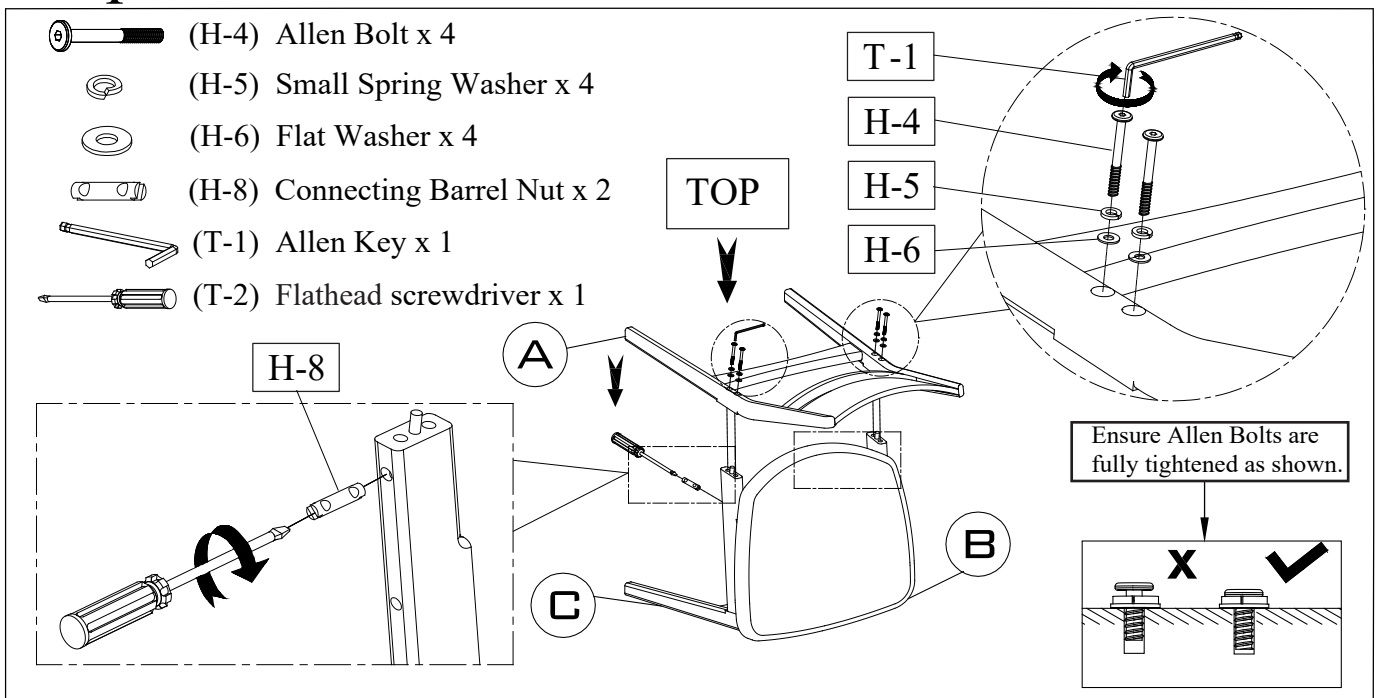

Place the partial assembly from Step 1 so that Seat (B) and Front Frame (C) are facing down towards the ground on a padded, non-marring surface. Next, place Back Rest (A) down into position as shown onto the alignment dowel on each wooden rail under Seat (B). Insert a Connecting Barrel Nut (H-8) through the bottom hole on each wooden rail under Seat (B) as shown in the bottom left detail illustration above. There are two threaded holes in the Connecting Barrel Nut (H-8) that should align with the corresponding holes of the Back Rest (A). Insert an Allen Bolt (H-4), Small Spring Washer (H-5), and Flat Washer (H-6) into each of those two holes of Back Rest (A) as shown, making sure the bolt engages the threads on Connecting Barrel Nut (H-8). It may help to hold the position of Connecting Barrel Nut (H-8) using a Flathead screwdriver (T-2 not included) while you hand thread the bolts. Engage the bolts by hand first, and then tighten them using Allen Key (T-1).

# Assembly Steps

## Step 3

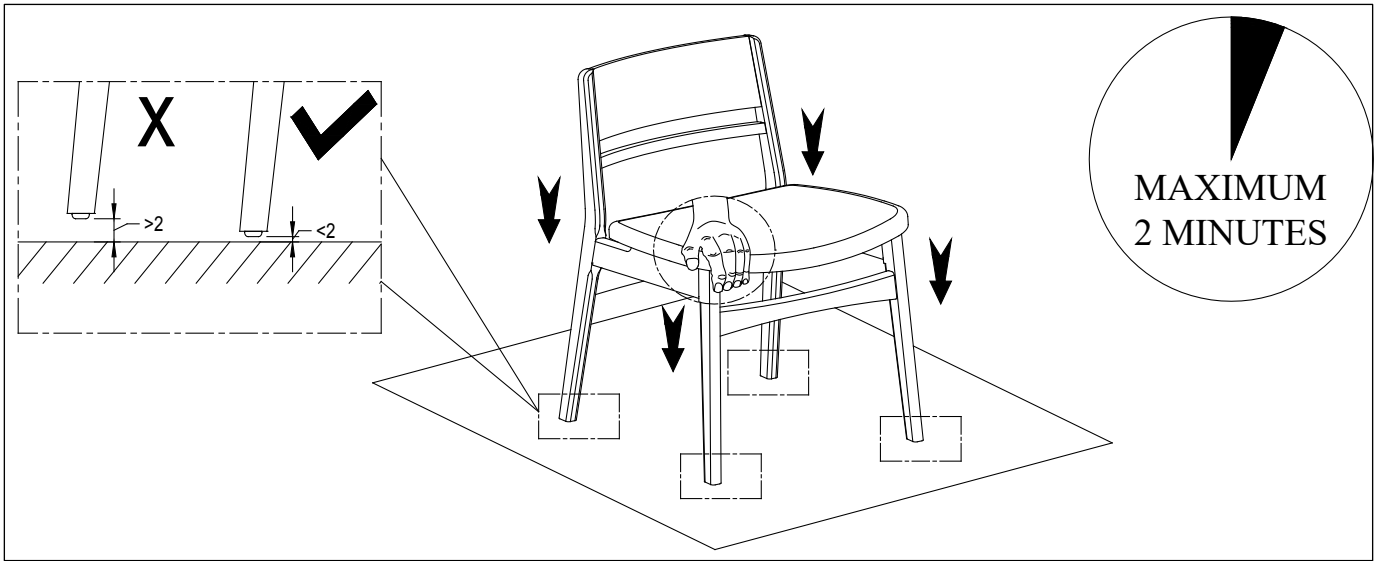

Carefully turn the assembly from Step 2 upright as shown. To ensure that all four legs of the chair rest evenly on the floor surface, spend 1-2 minutes applying moderate downward pressure to the chair seat deck as illustrated. Press down firmly at each corner of the seat using both hands, starting at the front of the chair and then moving to the back corners. Repeat the procedure as needed until verifying that the assembly has settled and any gaps between the legs and floor have been minimized. NOTE: Small (<2mm) gaps may still exist even after performing this step. This is normal production variance and does not impact the use of the chair once assembly has been completed.

## Step 4

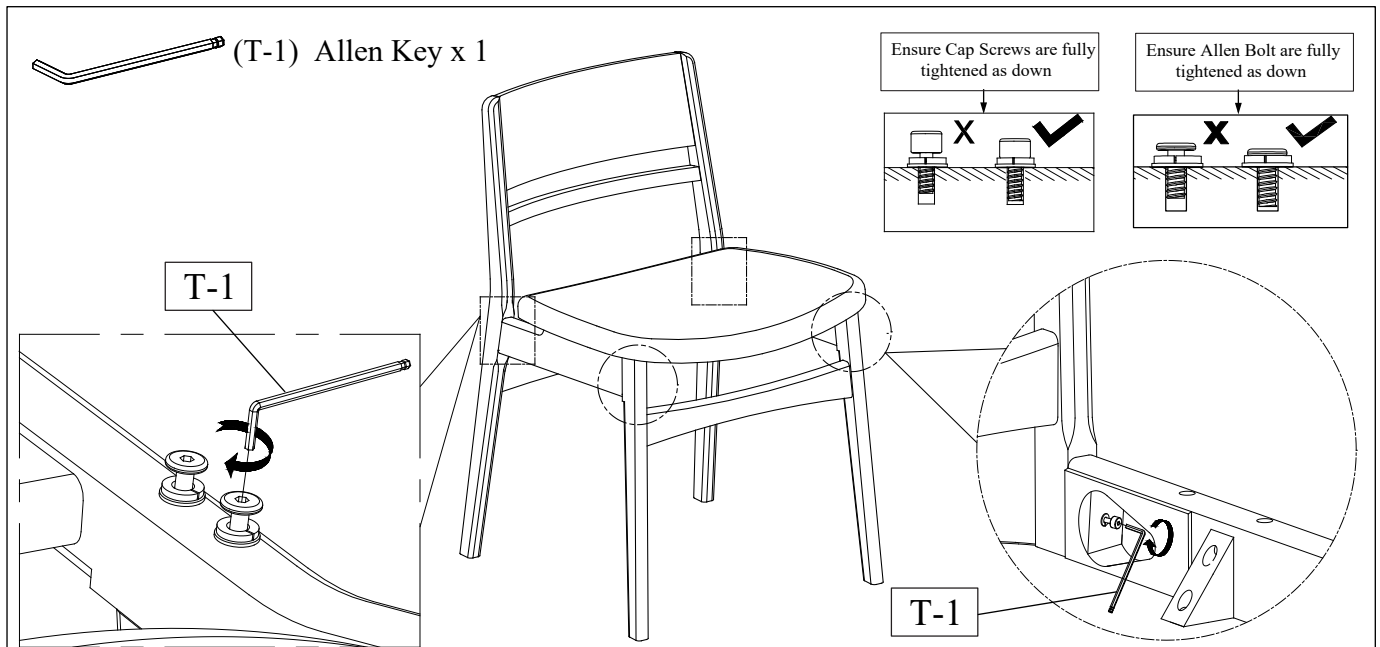

After verifying that all four legs have settled properly (in Step 3), fully tighten all bolts and cap screws from Step 1-2 using Allen Key (T-1). DO NOT use a power drill or overtighten any of the bolt hardware as this may damage the assembly.

# Assembly Steps

## Step 5

 (H-7) Wooden Plug x 4+1(Extra)

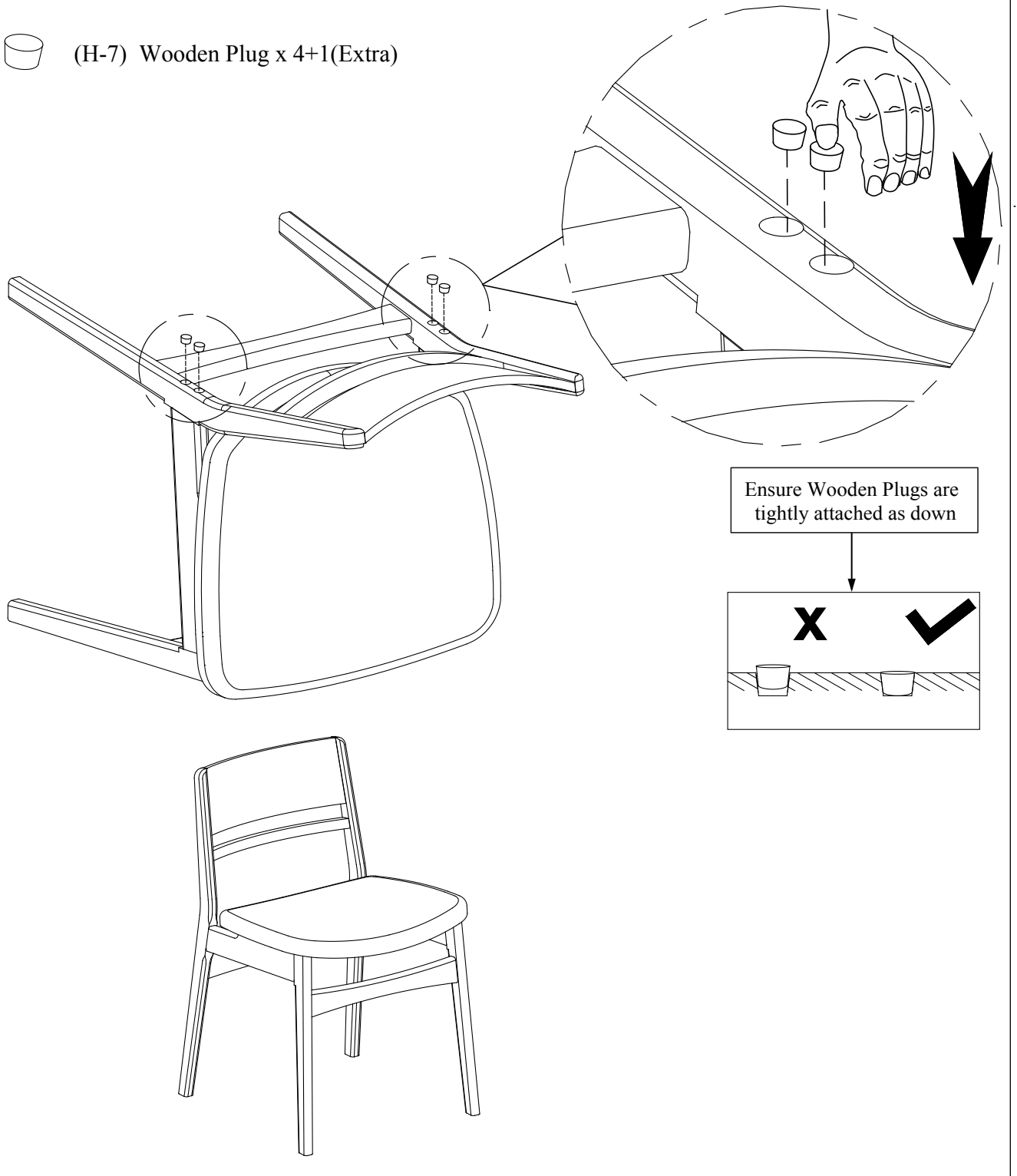

Use your hand to press Wooden Plug (H-7) into the holes in Back Rest as shown. One extra Wooden Plug (H-7) is provided. Assembly is now complete and the product is ready for use. NOTE: Hardware may loosen over time. Periodically check that all connections remain tight and adjust as needed.

# Warnings



All products sold at World Market are not for commercial use and are intended for residential use only.



**WARNING:** Small parts are a choking hazard. Adult supervision is required before, during and after assembly.

# Care & Maintenance



**DO NOT** put hot items directly on furniture surface.



**DO NOT** clean furniture with harsh cleansers or polish.

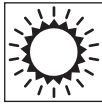

**DO NOT** place furniture in direct sunlight.



**DO NOT** place furniture near heating or cooling vents.



**DO NOT** write on furniture without a padded barrier to protect the surface.



**DO NOT** place furniture outside. For INDOOR USE ONLY.



Dust and pick up spills using a clean, non-colored, lint-free dry cloth.

# **WORLD MARKET** LIMITED ONE-YEAR WARRANTY – Indoor Furniture

For your customer satisfaction, this product carries a LIMITED ONE-YEAR WARRANTY from the date of delivery. This limited warranty only applies to World Market brand furniture, and not to other furniture brands sold on World Market's website.

Where applicable, the limited warranty provides coverage for:

1. **Manufacturing, Material and Workmanship Defects:** Includes defects related to core frame/structure substrates (wood and metal); cracking, splitting, or complete breakage of hardwood, plywood or medium density fiberboard (MDF); cracking, splitting or lifting of wood veneer or laminated top surfaces caused by process failure; broken welds or improperly coated metal frame components (powder coating or painted); fabric or leather material defects including tears, misprints, fraying, crease marks, skip stitches or open seams; support webbing material and sinuous spring defects or damage, including method of attachment to frame; and other component failures that are a direct result of manufacturing or workmanship defects.
2. **Cushions & Cushions with Enclosed Steel Pocket Coils:** Failed or ruptured steel pocket coils enclosed inside of seat cushions, or loss of resiliency from a material breakdown of foam or fiber filling, which should not be confused with softening or settling during normal use.
3. **Leather:** Splitting or cracking of leather material. NOTE: The warranty does NOT cover natural hide markings, variations in the leather color or grain due to the authentic natural properties of processed cowhide leather.
4. **Bonded Leather or Bi-cast Leather:** Separation of the polyurethane coating, peeling or cracking of the inner layer or at the bonded seam edges (bi-cast straps).
5. **Furniture Components (Hardware & Mechanisms):** Includes defects to pre-installed components or hardware provided to the customer for assembly such as office chair hydraulic lifts, lift mechanisms, metal bases and casters, swivel plate mechanisms; for drawers, metal glides, handles/knobs; for doors, hinges, magnetic latches; and other components such as bent or stripped threaded leg posts and adjustable levelers. For missing, damaged, corroded, or misplaced hardware components such as bolts or washers, please contact Customer Service at: 877-967-5362.

## **This LIMITED ONE-YEAR WARRANTY does NOT cover:**

1. Damage due to mishandling during transportation from store or transportation without original protective packaging.
2. Abuse, negligence (product misuse) or wear and tear that may result in or from:
  - a. **Wood & Veneer:** Mishandling, exposure to moisture, peeling or discoloration caused by exposure to moisture or excessive sunlight, heat; splintered, dented or nicked panels, legs or component edges or paint/finish blemishes; or treatment with corrosive chemicals (dyes, inks, paints or harsh cleaning products).
  - b. **Fabric & Leather (Including Bonded or Bi-Cast Leathers):** cuts, punctures, tears, burns, pet damage, or treatment with corrosive chemicals (dyes, inks, paints or harsh cleaning products), exposure to direct sunlight, fire, high heat, water, or any bright light source (natural or artificial) that may cause splitting, peeling or flaking with time.
  - c. **Foam (Cushions):** Flattening, relaxing or settling/softening of foam components that comes with normal use.
  - d. **Hardware Components:** improper installation or misuse/substitution of hardware components not defined in the Assembly Instructions for the product (if applicable)
3. Damage due to environmental exposure to direct sunlight, fire, high heat, water or extreme humidity, any bright light source (natural or artificial), or any environment that the product is not intended for.
4. This warranty is applicable for indoor furniture products purchased for residential use only.

For additional information on returns, please visit: <https://www.worldmarket.com/customer-service/return-policy.html>

**All products sold at World Market are NOT FOR COMMERCIAL USE and are intended for residential use only. Products purchased for commercial use will VOID all warranty provisions as listed above.**

Any claims under this LIMITED ONE-YEAR WARRANTY are valid and applicable only as to the original purchaser and must be accompanied by proof of purchase. Warranty claims should be submitted to a World Market store or through World Market Customer Service Call Center, Toll Free at 877-967-5362.

For valid warranty claims, World Market will repair or replace the product, or offer a full or partial credit, in the sole discretion of World Market. This LIMITED ONE-YEAR WARRANTY gives you specific legal rights and you may also have other rights which vary from state to state.